



MEDISMART COMPACT AVSU



Medi Smart Delivering innovative and reliable **Medical Engineering**, tailored for the GCC healthcare sector.



MEDISMART COMPACT

INTENDEND TO USE

MEDISMART COMPACT AVSUs are in single stage medical gas control the output pressure of the supply source to supply medical equipment via connections to terminal units or to be applied directly to the patient; and when necessary, to isolate between the supply source and the supply source and the utilization points. Medical gas monitoring and signaling systems valve box provide activation of medical gas flow, permanent monitoring of medical gas pressure including emergency supply of serviced area in the event of central medical gas supply failure.

These are designed to provide local isolation of individual parts of the central gas and vacuum piping system in the hospital, clinic or laboratory facility.

The Valve System Unit offers leak free connections as soon as they are installed to corresponding medical gas pipelines and are safe and easy to use.



FEATURES

- AVSU module with its local alarm pressure switches allows the ward staff to get immediate information on the actual state of the gas supply system.
- Area Valve Service Units, depending on request, may be surface or flush-mounting and are installed in electrostatic powder coated (RAL 9010) 1,5 mm thick DKP steel case panel.
- Robust body made of MS53 brass monoblock.

The doors incorporate a polycarbonate window featuring a pull ring far access to the valve in an emergency. This plug-unplug locking system is added to the cover system in order to intervene at the isolation valves in emergency conditions.

- The cover also incorporate the Local Alarm which the use of transducers will give a live reading to the pressure within the pipeline system.
- Pressure monitoring of the distribution system is done by pressure sensors and the pressure statuses are indicated on the alarm panel.

Control with input isolation valve.

- The valves feature Teflon seals flat face ease of connection to copper stub pipe assemblies.
- Gas special emergency service supply outlet at output (NIST).
- Forward facing NIST connectors with check valves plugs and caps, are also fitted.
- Perspective View and downstream of the valve
- The NIST connectors provide the facility to purge a system before the working gas is introduced, they also allow the pipeline pressure to be tested and gas samples to be taken.

MEDISMART COMPACT

- The units are also equipped with pressure switches and vacuum switch transmitting the low and high pressure conditions of the pressurized gases and low vacuum downstream of the zone control unit to the audible-visible alarm units.
- For maintenance and repair work, individual parts of the system can be shut-off without interrupting the whole gas supply.
- Area Valve Service Units available for oxygen, nitrous oxide, %50 oxygen / %50 nitrous oxide mixture, medical air, surgical air and medical vacuum.

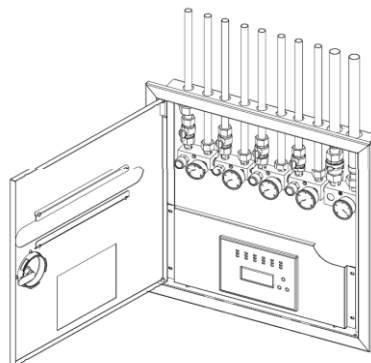
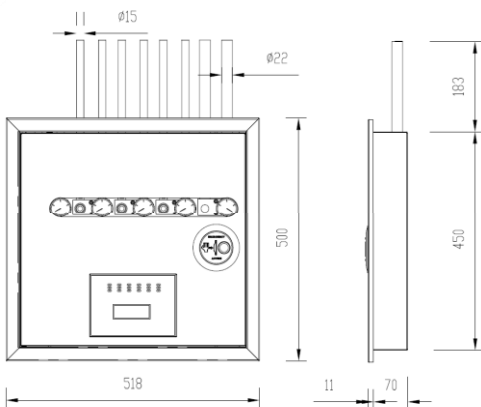



Medismart – Advancing healthcare with trusted, high-quality **Medical Engineering** across the GCC.



- Phone: +971 42 500 178
- Mobile: +971 55 585 2360
- Email: info@medismartglobal.com
- www.medismartglobal.com
- P.O. Box: 231673, Dubai